

# **Improvements in a “mature” technology: Metal Detectors**

1. Metal Detectors “State-of-the-Art”
2. Present Limitations
3. Trends & Future Enhancements

**IST Consultation Meeting, 22/9/1999**

**Claudio Bruschini**

École Polytechnique Fédérale de Lausanne (EPFL)  
& Vrije Universiteit Brussel (VUB)



Contact Address:

EPFL-LAMI, INF-Ecublens, CH-1015 Lausanne, Switzerland  
Claudio.Bruschini(AT)epfl.ch, <http://diwww.epfl.ch/lami/detec/> & <http://www.minedet.etro.vub.ac.be/>

## 1.1 Metal Detectors “State-of-the-Art”

### TECHNOLOGY:

- *Active, low frequency inductive systems* (eddy currents)
- **Continuos Wave:** one to a few frequencies at 1-30(50) kHz
- Transient (“**Pulse**”): pulse repetition ~ kHz, exponential decay time ~ several 100  $\mu$ sec. Broadband.
- **Background Reduction** of fundamental importance. Can be “physical” (ex. signal shape, differential coils) or “electronical” (signal processing).

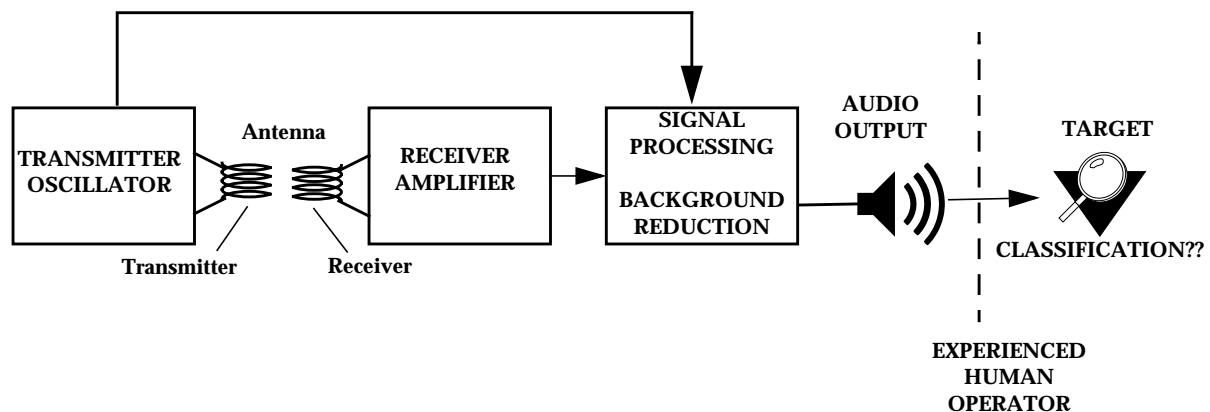

### MANUFACTURERS:

- Mostly specialized SME. Little technical/scientifical literature (IPR issues!).
- Strong European position. Installed base ~ 10000.
- Some increase in R&D outside the manufacturer area
- Strong similarities between mil. and hum. dem. systems



Contact Address:

EPFL-LAMI, INF-Ecublens, CH-1015 Lausanne, Switzerland

Claudio.Bruschini(AT)epfl.ch, <http://diwww.epfl.ch/lami/detec/> & <http://www.minedet.etro.vub.ac.be/>

## 1.2 Metal Detectors “State-of-the-Art”

**PORTABLE:** (Ebinger, Förster, Vallon (D); Schiebel (A); Guartel (UK); Minelab (AUS))

- **Weight:** less than 2 kg. **Price:** 2000-4000 EURO range.
- **Size:** round ( $\varnothing$  ~20-30cm), oval or rectangular head.
- **Operating depth:** shallow, i.e. from flush to 10-15cm for min-metal mines, 20-30cm for mines with appreciable metallic content, 50-70cm for larger metallic objects.

Can reach deeper using *large loop* detectors, as alternative/complement to magnetometers.

- **Electrical/Mechanical:** standard cell battery, tens of hours, simple to use (**ergonomics!**).
- **Output:** normally an audio signal (in some cases after extensive internal signal processing).

*Experienced operator -> qualitative statements on target and its position.*

**VEHICLE (ARRAY):** (Schiebel, TZN (D), Vallon, Förster in development, ...)

- *Aim: rapidly scan large areas*
- Mostly derived from commercially available technology
- As element in *Multisensor Systems*
- Importance growing for *UXO detection* (ex. site remediation)



## 2. Present Limitations

- “**False Alarm**” rate can be very high (1000:1) due to metallic debris (ex. former battlefields, urban areas)
- Reduced sensitivity in **mineralized soils**, sea water
- **Quantitative indications** on metallic target object **missing** (can obviously be very difficult due to background signal, unknown target, need not to fail)
- Development of **arrays** (for vehicles) is rather recent, still room for improvement
- Price reduction?



Contact Address:

EPFL-LAMI, INF-Ecublens, CH-1015 Lausanne, Switzerland  
Claudio.Bruschini(AT)epfl.ch, <http://diwww.epfl.ch/lami/detec/> & <http://www.minedet.etro.vub.ac.be/>

### 3.1 Trends & Future Enhancements

- MDs are likely to still be used for some time!
- Most **multisensor combinations** do contain a MD.

Some foresee to use the MD as “**primary sensor**” (ex. MD+GPR (HOPE), or MD+NQR, or MD+neutron (“slow” bulk explosive detection))

-> second sensor to analyze only the MD alarms: *MD false alarm rate reduction.*

- Further amelioration of **background rejection**
- The measured signal is rich in information:  $V=V(\sigma,\mu,R,d,...)$  -> study the possibility of delivering **quantitative information\***, for example:
  - **Depth**, using overlapping coils or signal profile study (scanning on a line over the object)
  - “**Size**”, possibly with a rough estimate (small (=debris?) vs. large)
  - **Object Type** (could be useful in situations where there are only a few targets in a given area)
  - **Object Shape** (not easy to reach sufficient resolution; useful for larger objects?)

*\*Practical usefulness debated, diverging opinions!*



### 3.2 Trends & Future Enhancements

- Some improvements should be possible using or slightly modifying existing sensors. Others may require more radical approaches:
  - **New types of sensors?** (ex. giant magnetoresistive elements, miniature fluxgate) 1D or 2D arrays should be feasible; sufficient sensitivity?
  - **New sensor geometries?** (ex. different coil arrangements)
  - **More complete measurements?** (full measurement of the induced magnetic field for example)
  - Combine with some form of “cavity detector”?
- Still some room for improvements of arrays

#### NEEDS:

- Feedback from deminers on object characterization usefulness
- Need for **details** of target objects (especially minimum-metal ones) and **detailed replicas**
- “Find” standalone applications for arrays (ex. QA/QC?)



Contact Address:

EPFL-LAMI, INF-Ecublens, CH-1015 Lausanne, Switzerland  
Claudio.Bruschini(AT)epfl.ch, <http://diwww.epfl.ch/lami/detec/> & <http://www.minedet.etro.vub.ac.be/>